

# Operating instructions

## SAT-TV Transmodulator

DVB-S/ S2 → DVB-C/ ITU-T J.83 Annex B, C



### Contents

1. Safety and operating instructions.....	2
2. Device variants .....	2
3. General .....	2
4. Front view .....	3
5. Functional description.....	3
6. Adjustments .....	3
6.1 Adjustment with the Headend Controller .....	3
6.2 Adjustment with PC/ laptop .....	3
6.2 Adjustment with SNMP .....	3
7. Meaning of status LED's .....	4
8. Programming by web server .....	4
8.1 Main menu .....	4
8.2 Extended settings .....	5
8.3 Table processing .....	5
8.4 NIT entries .....	5
8.5 Configuration channel list-LCN .....	5
8.6 Program filter .....	6
8.7 Data rate overview .....	6
8.8 Device status .....	6
8.9 Software overview .....	7
8.10 Factory settings .....	7
9. Manual menu control with Headend Controller .....	8
10. SNMP trap messages .....	8
11. Block diagram .....	9
12. Head end bus structure .....	9
13. Application example.....	10
14. Technical data ... ..	11
15. Glossary.....	11
16. Bibliography .....	12
17. Document history .....	12



## STB 016

## Part N°: 9710.02

## 1. Safety and operating instructions



When assembling, starting-up and adjusting the modules, it is necessary to consider the system specific references in the manual instruction.



The modules may only be installed and started up by authorized technical personnel.



When assembling the modules into the receiving points, the adherence of the EMC regulations is to be secured.



The assembly and wiring have to be done without voltage.



All active modules may only be operated with the Headend Controller HCB x00 or Bus Extender BEB x00.



The main voltage and the operating voltage of the modules working by DC have to be in compliance to the operating parameters described in the technical data.



With all work the defaults of the DIN EN 50083 have to be considered. Especially the safety relevant execution of the DIN EN 60728-11[4] is necessary.



WEEE-Reg.-Nr. DE 50389067

## 2. Device variants

STB 016    9710.02    DVB-S/ S2 → DVB-C/ ITU-T J.83 Annex B, C

### Minimum software requirements for HCB x00:

9650.03:    version 2.34\*  
9650.04/.05: version 3.18\*  
9652.01:    version 3.23\*  
9653.01:    version 3.27\*  
9653.02:    version 3.28\*

\*) Updates: [www.blankom.de](http://www.blankom.de)

## 3. General

The SAT-TV transmodulator STB 016 is a module of the head end system B-LINE which is conceived as a complete system for middle-sized networks. The module converts one DVB-S/ S2 transponder into the digital cable standard DVB-C or ITU-T J.83 Annex B or C. The signals will be transcoded into cable TV channels. All modules will be programmed via a central control unit (HCB x00) and are working fully independent afterwards. The status of the modules are displayed via LED's (see chapter 7 "Meaning of status LED's").

### 4. Front view

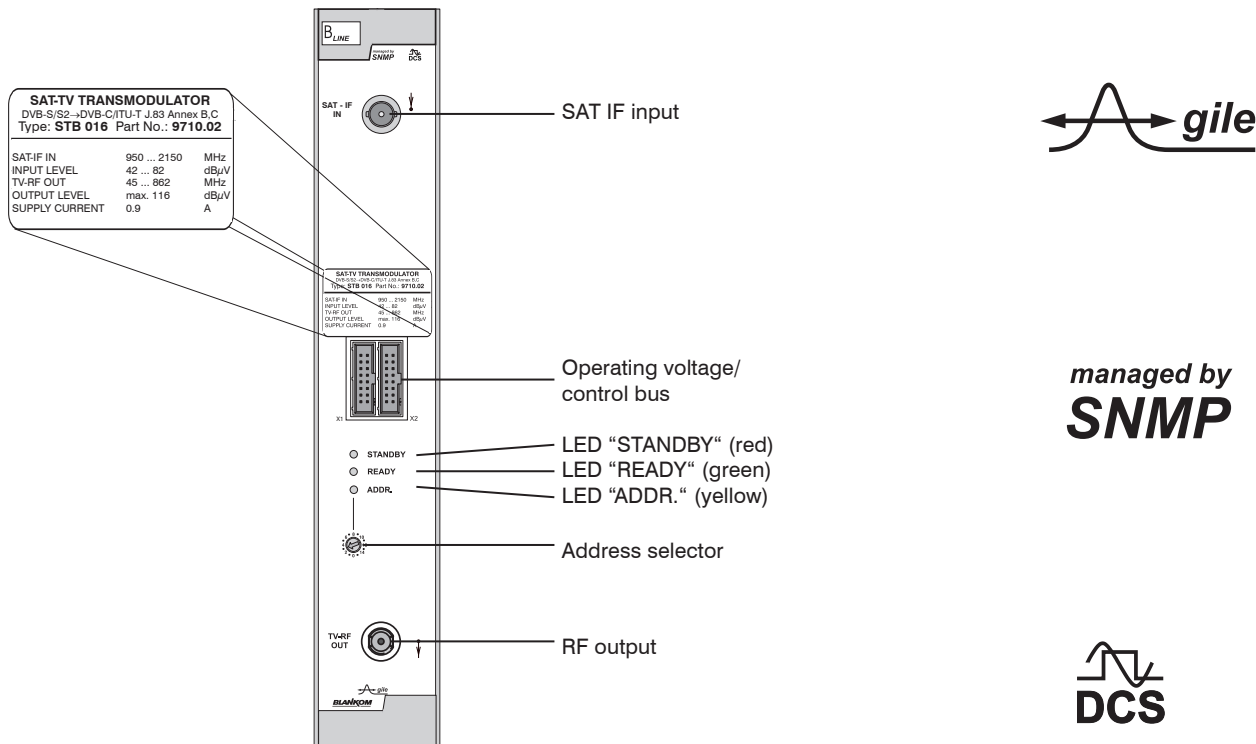

### 5. Functional description

The SAT IF input signal is fed to the DVB-S/ -S2 front end, where the selection of a transponder and its QPSK or 8PSK demodulation is done and a data stream is generated. All services of the resulting transport stream which shall be processed into the QAM modulator will be chosen by controlling software of the module. The SI and PSI tables affected (i.e. the PAT, PMT, SDT, EIT) are automatically corrected. The Headend Controller serves to generate an NIT (Network Information Table) into the transport stream. This is required to enable the receiver (such as Set-Top-Box) to tune in automatically. The changed SI and PSI tables are fed into the QAM modulator and an IF signal is generated at the output channel. There is a free choice of frequency in the output channel from 45 to 862 MHz. On the output side, the modulator does not leak to adjacent channels. So that errors in level can be signalled if the load fluctuates (the red LED will flash and a trap message will be sent), a reference level is generated. Every time the level for frequency figures are programmed, automatic measurement of the reference level takes place; this function will, however, not start until 100 seconds have elapsed after start-up of the system. This function can be enabled or disabled in the main menu.

### 6. Adjustments

#### 6.1 Adjustment with the Headend Controller

- Adjustment of the addresses at the Bus Extender BEB x00 and at the modules
- Activation of the programming mode on each module by selecting the line (BEB x00) and the module position (01... 15) at the Headend Controller (HCB x00) → yellow LED illuminates until the beginning of the parameter adjustment
- Adjustment of the STB 016 parameters (see chapter 9) → green LED is switched on
- After the programming the STB 016 will be automatically switched into the operating mode → yellow LED flashes shortly/ green LED is switched on

#### 6.2 Adjustment with PC/ laptop

- Prerequisite for the remote programming is an “online-connection” according to the IP standard and an ethernet connection at the PC/ laptop
- Adjustment of the line/ position addresses at the Bus Extender BEB x00 as well as at the modules
- At the Headend Controller HCB x00 input IP address (default: 192.168.2.80)
- For “direct connection” between a PC and HCB x00 use crossover cable (RJ 45)
- For connection over a hub use a normal straight through patch cable
- Start-up HTML browser and put in IP address as target address
- If connected correctly the web interface will be opened on the PC/ laptop and a blue LED (LINK) at the HCB x00 will be lit up.
- All adjustments of the modules are specified on the web interface.

#### 6.3 Adjustment with SNMP

- Prerequisite for the SNMP functionality is the use of HCB x00 with enabled SNMP software option CKB 100.
- Supported is SNMP version 1.0 [3].
- Automatic creation of the MIB based on the current head end configuration by the HCB x00.
- For setting and reading out the parameters and is to receive traps from an SNMP management software required.
- Further notes on the SNMP functionality of BLANKOM modules are listed in the SNMP manual (download: [www.blankom.de](http://www.blankom.de)).

**The manual instructions of the Headend Controller HCB x00 and the Bus Extender BEB x00 have to be considered!**

### 7. Meaning of status LED's

Designation (Colour))	Status	Meaning of display
STANDBY (red)	permanently on	Module is on standby
	flashing	Module faulty (hardware) or level error
READY (green)	permanently on	Module working, everything ok
	flashing	Dysfunction depending in signal: Tuner not sync (e.g. in case of missing input signal) no input on the QAM modulator buffer overflow in the QAM modulator QAM overflow (input data rate on the QAM modulator too large)
	off	RF output is deactivated
ADDR. (yellow)	illuminated or flashing	Remote control making contact/ data transmission

### 8. Programming by web server \*

#### 8.1 Main menu

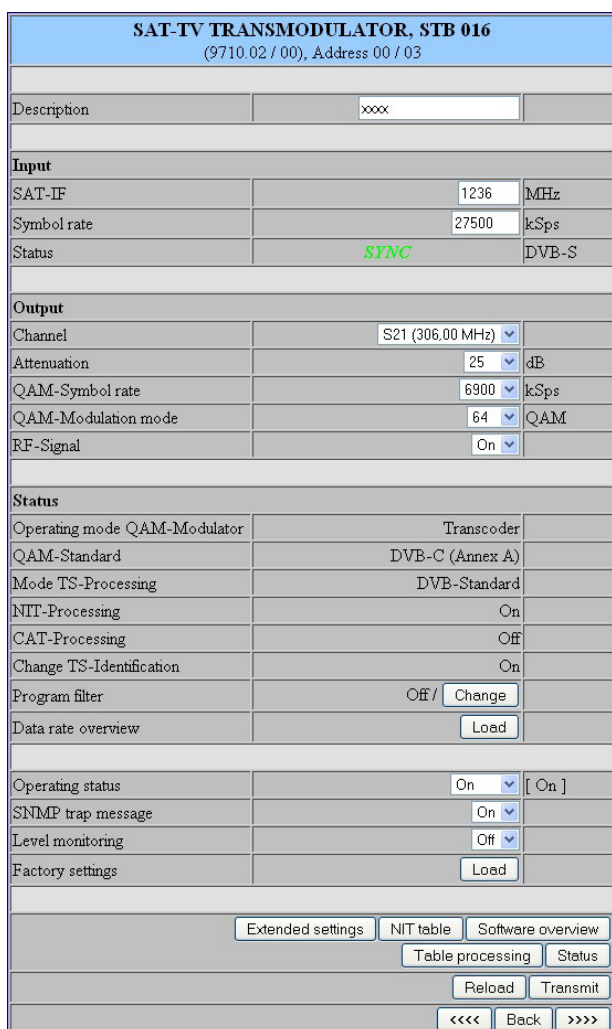

Name of device, item number, module address in head end

Description module name (max. 30 characters)

#### Input

SAT-IF adjustment range: 950 ... 2150 MHz  
Symbol rate adjustment range: 2000 ... 45000 MSps  
Status display wether **SYNC**hronization or **noSYNC**hronisation with input

#### Output

Channel channel selection accord. QAM standard:  
DVB-C/ Annex A: 2 ... 69, standard B/G  
Annex B, C: 2 ... 134, standard M  
Attenuation adjustment range: 0 ... 31.5 dB  
QAM-Symbol rate selection: 6995, 6900, 6875, 6111, 6000, 3450, 1750 kSps

QAM-Modulation mode selection: 16, 32, 64, 128, 256 QAM  
RF-Signal selection: On/ Off

#### Status

Operating mode QAM-Modulator according adjustment menu 1  
QAM-Standard DVB-C (Annex A)/ ITU-T J.83B (Annex B)/ ITU-T J 83C acc. adjustment menu 1  
Mode TS-Processing DVB-Standard/ TNT-France acc. menu 1  
NIT-Processing On/Off according adjustment menu 2  
CAT-Processing On/Off according adjustment menu 2  
Change TS-Identif. On/Off according adjustment menu 2  
Program filter see menu 5  
Data rate overview see menu 6

Operating status selection: On/ Off/ Reset  
SNMP trap message selection: On/Off,if SNMP option in HCBx00 enabled, otherwise „locked“ display  
Level monitoring On/ Off  
Factory settings setting the default values (see menu 9)

Routing to the appropriate adjustment menu

Extended settings see menu 1  
NIT table see menu 3  
Software overview see menu 8  
Table processing see menu 2  
Status see menu 7

\* Further details on this are to be found in the HCB manual

### 8.2 Extended settings (menu 1)

**SAT-TV TRANSMODULATOR, STB 016**  
(9710.02 / 00), Address 00 / 03

**Output**

Frequency	306000	kHz
QAM-Symbol rate	6900	kSps
Spectrum inversion	normal	
QAM-Standard	DVB-C (Annex A)	
Operating mode QAM-Modulator	Transcoder	
Mode TS-Processing	DVB-Standard	

Reload Back Transmit

Name of device, item number, address in head end

#### Output

Frequency adjustment range: 45000 ... 862000 kHz  
 QAM-Symbol rate adjustment range: 1000 ... 7200 kSps  
 Spectrum inversion selection: normal/ invers  
 QAM-Standard selection: DVB-C (Annex A), ITU-T/ J.83B (Annex B), ITU-T/ J.83C (Annex C)  
 Operating mode QAM-Modulator selection: Transcoder, Test level, Test signal

### 8.3 Table processing (menu 2)

**SAT-TV TRANSMODULATOR, STB 016**  
(9710.02 / 00), Address 00 / 03

**NIT**

NIT-Processing	On	
Network name	Blankom	
Network ID	10	dez
Channel number insertion (LCN)	On	
Standard SD-LCN	NorDig(V1)	
Channel list	Configure	

**CAT**

CAT-Processing	Off	
CA-System ID	0	dez
Operator ID	0	dez

**Transport stream**

Change TS-Identification	On	
Transport stream ID	10	dez
Network ID	20	dez

Reload Back Transmit

Name of device, item number, module address in head end

#### NIT

NIT-Processing selection: On/ Off  
 Network name adjustment range: max. 30 characters  
 Network ID adjustment range: 0...65535  
 Channel number insertion (LCN) selection: On/ Off  
 Standard SD-LCN IEC 62216, NorDig(V1)  
 Channel list see menu 4

#### CAT

CAT-Processing selection: On/ On (CA Filter)/ Off  
 CA-System ID adjustment range: 0...65535  
 Operator ID adjustment range: 0...65535

#### Transport stream

Change TS-Ident. selection: On/ Off  
 Transp. stream ID adjustment range: 0...65535  
 Network ID adjustment range: 0...65535

### 8.4 NIT entries (menu 3)

**SAT-TV TRANSMODULATOR, STB 016**  
(9710.02 / 00), Address 00 / 14

Entry	Original TS-ID	Original Network ID	Frequency (kHz)	QAM Symbolrate (kSps)	Modulation (QAM)
1	1101	1	306000	6900	64

NIT distribution: dynamically  
 Network name: none  
 Network ID: 0

Reload Back

Name of device, item number, address in head end

NIT entries with all information available

### 8.5 Configuration channel list-LCN (menu 4)

**SAT-TV TRANSMODULATOR, STB 016**  
(9710.02 / 00), Address 00 / 03

Program name	Service ID	LCN (SD)		HD simulcast LCN	
		Channel number	Activated	Channel number	Activated
Das Erste	0x6DCA	10	<input checked="" type="checkbox"/>	50	<input checked="" type="checkbox"/>
Bayarisches FS Sud	0x6DCB	11	<input checked="" type="checkbox"/>	51	<input checked="" type="checkbox"/>
hr-fernsehen	0x6DCC	12	<input checked="" type="checkbox"/>	52	<input checked="" type="checkbox"/>
Bayarisches FS Nord	0x6DCE	13	<input checked="" type="checkbox"/>	53	<input checked="" type="checkbox"/>
WDR Köln	0x6DCF	14	<input checked="" type="checkbox"/>	54	<input checked="" type="checkbox"/>
SWR Fernsehen BW	0x6DD1	15	<input checked="" type="checkbox"/>	55	<input checked="" type="checkbox"/>

Reload Back Transmit

Name of device, item number, module address in head end

The allocation of a logical channel number (LCN) is a service that allocates a serial number to each TV activated program. If the set-top box supports this service at the subscriber, the TV programs are offered in the order established by program numbers. It should be noted that the numbering is done separately for HD and SD programs for the respective type of the box. The simultaneous activation and number allocation for SD programs in the HD column provides such programs to the appropriate channel number in the program list for HD boxes.

### 8.6 Program filter (menu 5)

SAT-TV TRANSMODULATOR, STB 016 (9710.02 / 00), Address 00 / 14		
<b>Program filter configuration</b>		
Filter function		Off
Other transponder information		Pass
<b>Program selection</b>		
Operating mode		Drop
Service ID	Program name	Selection
0x6DCA	Das Erste	<input checked="" type="checkbox"/>
0x6DCB	Bayerisches FS Süd	<input checked="" type="checkbox"/>
0x6DCC	hr-fernsehen	<input type="checkbox"/>
0x6DCE	Bayerisches FS Nord	<input type="checkbox"/>
0x6DCF	WDR Köln	<input checked="" type="checkbox"/>
0x6DD0	BR-alpha*	<input type="checkbox"/>
0x6DD1	SWR Fernsehen BW	<input checked="" type="checkbox"/>
<input type="button" value="Reverse selection"/> <input type="button" value="Select all"/> <input type="button" value="Clear all"/>		
<input type="button" value="Data rate overview"/>		
<input type="button" value="Reload"/> <input type="button" value="Back"/> <input type="button" value="Transmit"/>		

Name of device, item number, address in head end

**Program filter configuration**  
 Filter function selection: On/ Off  
 Other transponder information pass or drop of additional informations (e.g. electronic program guide), which are contained in data stream as "other"

**Program selection**  
 Operating mode pass or drop of the marked programs

Reserve selection all not marked programs are chosen or vice versa  
 Select all all programs of the list are marked  
 Clear all no program of the list is marked  
 Data rate overview routing to menu 6

### 8.7 Data rate overview (menu 6)

SAT-TV TRANSMODULATOR, STB 016 (9710.02 / 00), Address 00 / 03		
Input data rate	38.016	MBit/s
Data rate by filter	34.686	MBit/s
max. QAM-Data rate	38.152	MBit/s
<b>Reserve</b>	<b>3.465</b>	MBit/s
FIFO-Memory utilisation	0	%
<input type="button" value="Reload"/> <input type="button" value="Back"/>		

Name of device, item number, address in head end

Input data rate net data rate at the input  
 Data rate by filter net data rate by program filters  
 max. QAM Data rate max. possible net data rate  
**Reserve** max. QAM data rate minus data rate by filter

FIFO-Memory utilisation displays in %

### 8.8 Device status (menu 7)

SAT-TV TRANSMODULATOR, STB 016 (9710.02 / 00), Address 00 / 14		
<b>Tuner</b>		
Status	SYNC	
Mode	DVB-S	
Set values	Sat ZF:1237 Symbolrate:27505	
BER	<1.192E-07	
Input data rate	38.014	MBit/s
<b>FPGA Status</b>		
FPGA Status	Transport stream OK	
FPGA error memory	empty	
Up Converter error memory	empty	
<b>Original TS-ID's</b>		
Original TS-ID's	TS-ID: 1101 Network-ID: 1	
<b>Information</b>		
Temperature	87 °F	
Device number	0000000	
Device index	00	
<input type="button" value="Reload"/> <input type="button" value="Back"/>		

Name of device, item number, address in head end

**Tuner**  
 Status displays whether **SYNC**hronization or **noSYNC**hronization  
 Mode format of transmission  
 Set values displays SAT IF and symbol rate  
 BER bit error rate  
 Input data rate displays net data rate

**FPGA Status**  
 FPGA Status status, transport stream input  
 FPGA error memory error memory TS mux, QAM modulator  
 Up Converter error memory error memory up converter

**Original TS-ID's**  
 Original TS-ID's displays transport stream ID and network ID

**Information**  
 Temperature temperature of terminals board  
 Device number display of the device number  
 Device index display of the device index (hardware)

**8.9 Software overview (menu 8)**

SAT-TV TRANSMODULATOR, STB 016 (9710.02 / 00), Address 00 / 14	
Version	
AP Controller	9710.02-81.01 Steuercontroller Anschluss-LP V1.06 18.02.2009 JR
FPGA Boot Controller	9710.02-88.01 FPGA Boot Controller(2) V1.02 24.04.08 JR
FPGA	9710.02-87.01 TS-Mux;QAM-Modulator V1.05 13.01.2009 WE,JR
Nios	9710.02-86.01 TS-Manager V1.04 20.02.2009 JR
S2-NIM Controller	9619.05-88.02 S2-NIM-Controller H2V1.02 07.06.2006 PK
Up Converter	9199.01-88.02 internal Controller V2.00 26.06.2008 JH
Back	

Name of device, item number, address in head end

**Software version**

Controller of terminals board

FPGA boot controller

QAM modulator, TS-Mux (FPGA)

TS manager

S2-NIM controller

Up Converter controller

**8.10 Factory settings (menu 9)**



When request this menu item at first a security query whether it really set all parameters to the factory default settings pops up.

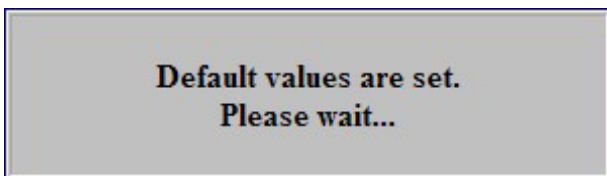

Affirming the query, all settings made on the EEPROM will be deleted and replaced by the default settings. The modul will go back to these default values. Once the setting process is over, there will be automatic return to the main menu. It takes about one minute.

## 9. Manual menu control with Headend Controller (HCB x00)

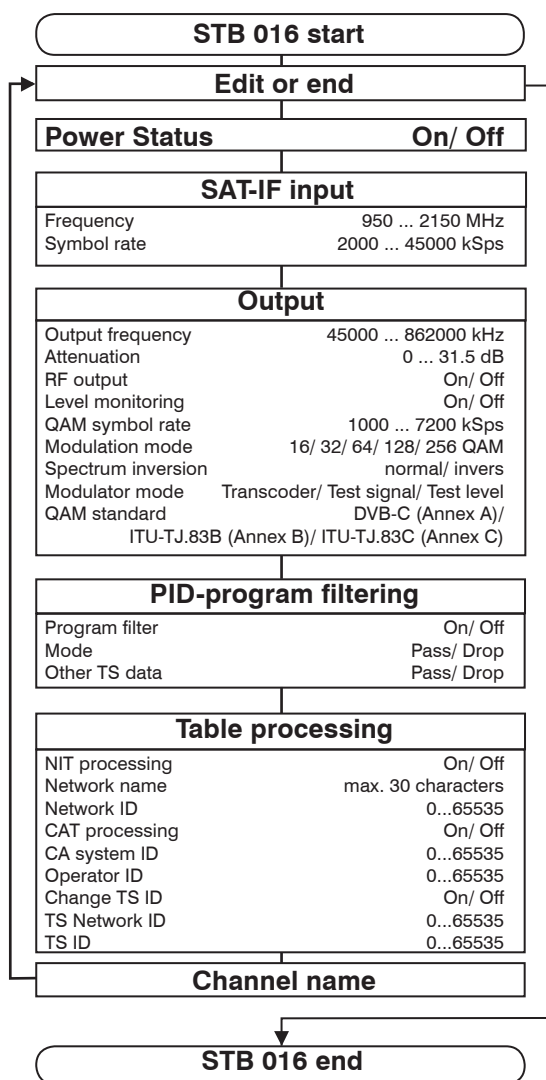

## 10. SNMP trap messages

Item	Message	Message type	Message
01	Power fail	CRITICAL	short circuit
02	System Reset	WARNING	reset by internal error
03	Signal OK	INFORMATION	module works correctly
04	Tuner not sync	WARNING	no input signal at the tuner
05	IIC error	CRITICAL	IIC bus error
06	TS-MUX not sync	WARNING	no transport stream at the FPGA
07	Internal controller reset	WARNING	error when accessing internal controller
08	FPGA: Program memory full	WARNING	overflow of program memory in the FPGA
09	FPGA: PID memory full	WARNING	overflow of PID memory in the FPGA
10	FPGA: Directory full	WARNING	overflow of Directory in the FPGA
11	FPGA: FAT memory full	WARNING	overflow of FAT memory in the FPGA
12	FPGA: TS-Packed buffer overflow	WARNING	overflow of TS packet buffer
13	QAM overflow	CRITICAL	overflow of QAM
14	Sync error data FIFO	CRITICAL	data FIFO doesn't work correctly
15	No response to OPEN command	CRITICAL	error internal port



Item	Message	Message type	Message
16	Up Converter: PLL1 not locked	CRITICAL	no funktion at the PLL 1 converter
17	Up Converter: PLL2 not locked	CRITICAL	no funktion at the PLL 2 converter
18	Up Converter: IF input too small	WARNING	IF input too small at the upconverter
19	Up Converter: IF input too large	WARNING	IF input too large at the upconverter
20	Up Converter: RF output too small	WARNING	RF output too small at the upconverter
21	Up Converter: RF output too large	WARNING	RF output too large at the upconverter

## 11. Block diagram

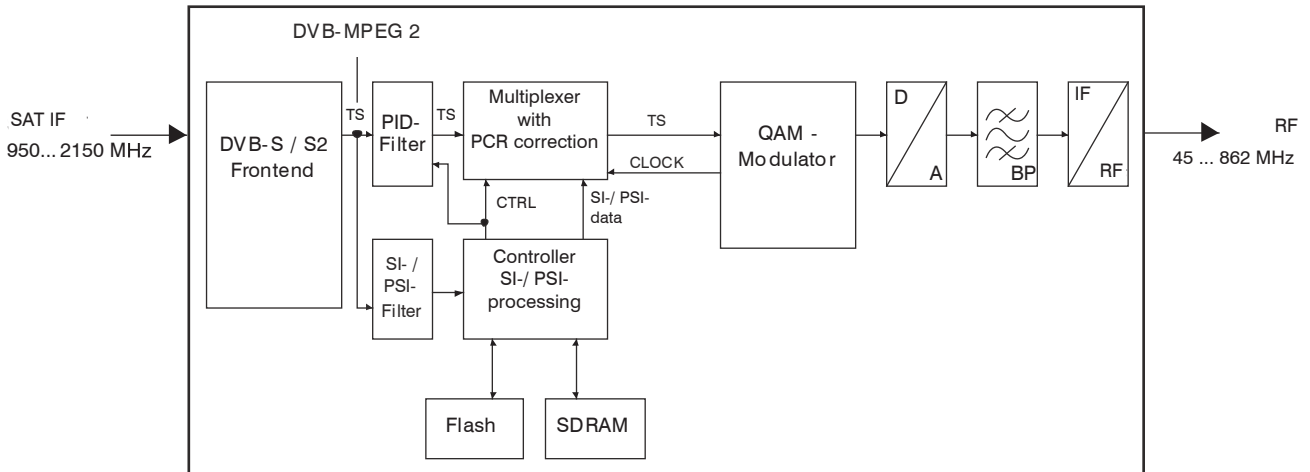

## 12. Head end bus structure

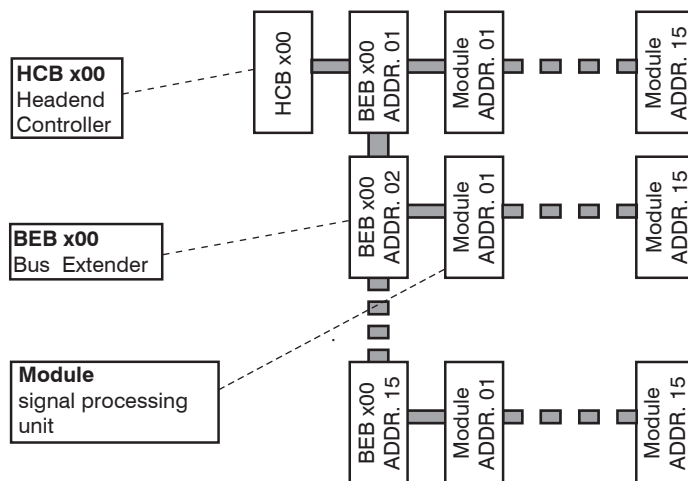

The number of the possible module connections (01 ... 15) to a BEB x00 depends on the total power consumption of this line!

**13. Application example**

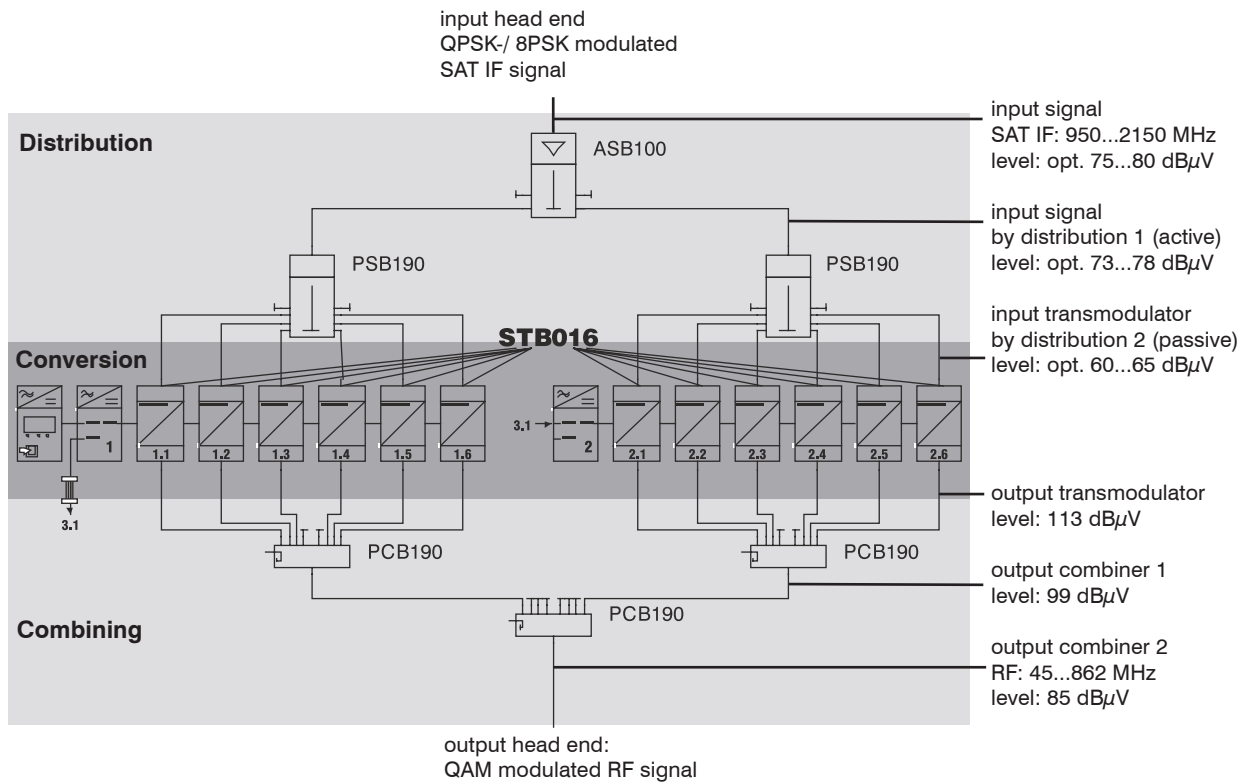

**14. Technical data****SAT IF input**

Frequency range	950...2150 MHz
Frequency step	1 MHz
AFC range	± 3 MHz (SR < 10 MSps) ± 5 MHz (SR ≥ 10 MSps)
AGC level range	42 ... 82 dBμV
Connector	F socket
Impedance	75 Ω

**DVB-S demodulator (QPSK)**

Symbol rate	2...45 MSps
Code rate (Viterbi)	1/2, 2/3, 3/4, 5/6, 7/8
Roll off	35 %
Signal processing	ETS 300 421 [1]

**DVB-S2 demodulator (QPSK, 8PSK)**

Symbol rate	QPSK 1...34 MSps 8PSK 1...28.9 MSps
Code rate (LDPC)	QPSK 1/4, 1/3, 2/5, 1/2, 3/5, 2/3, 3/4, 4/5, 5/6, 8/9, 9/10 8PSK 3/5, 2/3, 3/4, 5/6, 8/9, 9/10
Roll off	20, 25, 35 %
Signal processing	ETS 302 307 [2]

**QAM modulator**

Input data rate	max. 78 Mbps according adjustment symbol rate & QAM constellation
Symbol rate	1.0...7.2 MSps
QAM modulation	ITU-T J.83 Annex B, C, DVB-C

	<b>Annex B</b>	<b>Annex C</b>	<b>DVB-C</b>
QAM constell.	64; 256	64	16; 32; 64; 128; 256
Roll off	12 %, 18 %	13 %	15 %
Interleaving	Conv. I=128, J=4	Conv. I=12	Conv. I=12
Forward error correction (FEC)	Reed Solomon (128,122) + Trellis	Reed Solomon (204, 188,8)	Reed Solomon (204, 188,8)

Test signals	according adjustment symbol rate & QAM constellation
Measurement signal	unmod. carrier (signal level)
PSI-/ SI processing	disconnectable
Zero stuffing	continuously
Signal processing	EN 300 429 [3] ITU-T J.83 Annex B, C [5]

**RF output**

Output frequency range	45 ... 862 MHz
Tuning step	125 kHz
Max. output level	116 dBμV
Level adjustment range	0 ... 31.5 dB (0.5 dB steps)
Channel allocation	adjacent channel ability
Connector	F socket
Impedance	75 Ω
Return loss	≥ 18 dB 45 MHz - 1.5 dB/ octave

**Signal quality**

MER	≥ 45 dB
Shoulder attenuation	≥ 58 dB
Spurious 45...862 MHz	≥ 60 dB
C/N (> 25 MHz space from channel center)	
BW = 4,8 MHz	typ. 80 dB
BW = 6 MHz	typ. 79 dB
BW = 8 MHz	typ. 78 dB
Phase noise	1 kHz; typ. -92 dBc/ Hz 10 kHz; typ. -101 dBc/ Hz 100 kHz; typ. -108 dBc/ Hz
max. frequency stability	30 kHz
Output level stability	± 0.5 dB
Amplitude frequency response channel (8 MHz)	max. 1 dB <sub>pp</sub>

**Operating parameters**

Voltage/ current	12 V (± 0.2 V)/ max. 900 mA
Residual ripple of the supply voltage	10 mV <sub>pp</sub>

**Environmental conditions**

Temperature range	-10 ... +55 °C
Temperature range for data keeping	5 ... 45 °C
Relative humidity	≤ 80 % (non condensing)
Method of mounting	vertical
Location of mounting	splash-proof and drip-proof

**Miscellaneous**

Dimensions (l x w x h)	
without 19" - adapter	50 x 276 x 148 mm
with 19" - adapter	50 x 301 x 148 mm
Weight	1,190 g

**Delivery content**

1x bus connector

**15. Glossary**

8PSK  
AFC  
AGC  
APL  
BER  
BW  
CA  
CAT  
DVB  
EIT  
ETSI  
FAT  
FEC  
FPGA  
HTTP  
I/Q  
ID  
IF  
IIC  
IP

**8 Phase Shift Keying**  
**Automatic Frequency Control**  
**Automatic Gain Control**  
**Anschlussplatte** (Terminals board)  
**Bit Error Ratio**  
**Bandwidth**  
**Conditional Access**  
**Conditional Access Table**  
**Digital Video Broadcasting** (-C Cable, -S Satellite, -S2 Satellite 2, -T Terrestrial)  
**Event Information Table**  
**European Telecommunications Standards Institute**  
**File Allocation Table**  
**Forward Error Correction**  
**Field Programmable Gate Array**  
**Hypertext Transfer Protocol**  
**In-phase/ Quadrature-phase**  
**Identifier**  
**Intermediate Frequency**  
**Inter-Integrated Circuit** (I<sup>2</sup>C-Bus, data bus within device)  
**Internet Protocol**

LDPC	Low Density Parity Check Code
LED	Light Emitting Diode
MAC	Media Access Control
MER	Modulation Error Ratio
MIB	Management Information Base
MPEG	Moving Picture Experts Group
MPTS	Multi Program Transport Stream
NIM	Network Interface Module
Nios	product name for a processor
NIT	Network Information Table
PAT	Program Association Table
PCR	Program Clock Reference
PID	Program Identifier
PMT	Program Map Table
PSI	Program Service Information
QAM	Quadrature Amplitude Modulation
QPSK	Quadrature Phase Shift Keying
RF	Radio Frequency
SDT	Service Description Table
SI	Service Information
SNMP	Single Network Management Protocol
SPTS	Single Program Transport Stream
TS	Transport Stream

## 16. Bibliography

- [1] EN 300 421: Digital Video Broadcasting (DVB): Framing structure, channel coding and modulation for 11/ 12 GHz satellite services
- [2] EN 302 307: Digital Video Broadcasting (DVB): Second generation framing structure, channel coding and modulation systems for Broadcasting, Interactive Services, News Gathering and other broadband satellite applications
- [3] EN 300 429: Digital Video Broadcasting (DVB): Framing structure, channel coding and modulation for cable systems
- [4] EN 60728-11: Cable networks for television signals, sound signals and interactive services Part 11: Safety (IEC 60728-11:2005); German version EN 60728-11:2005
- [5] ITU-T J.83 Digital multi-programme systems for television, sound and data services for cable distribution, Amendment to Annex B and C (2006)
- [6] EN 50083-2 : Cabled distribution systems for television and sound signals. Electromagnetic compatibility for equipment; EN 50083-2:2001
- [7] RFC 1157 Request for Comments (RFC): RFC Database URL: [Http://www.rfc-editor.org/rfc.html](http://www.rfc-editor.org/rfc.html)

## 17. Document history

Version	Date	Modification	Author
1.00	18.07.2008	basic document	Poch
1.01	03.09.2009	revision	Häußer
1.02	13.02.2012	revision web sites (LCN)	Häußer

# Declaration of Conformity

## The Manufacturer

BLANKOM Antennentechnik GmbH · Hermann-Petersilge-Str. 1 · 07422 Bad Blankenburg · Germany

herewith declares the conformity of the product

**Product name:** SAT-TV Transmodulator

**Type:** STB 016

**Product number:** 9710.02

according to the following regulations

EN 50083-2

EN 60728-11 (as far as relevant)

and additional device-specific regulations, enclosed above, which this product is subjected to.

**Date:** 03.09.2009

**Signature:**



(Managing Director)